

Introduction of NSTCCore Computing & Storage Services

<https://nstccore.twgrid.org>

15 January, 2025

Introduction of NSTCCore Computing Service

- *Funding from both Academia Sinica & NSTC(國科會)*
- Computing Service
- Storage Service
- Technical Support
- User Management

	2024.04 ~	2024.09~2025.08	2025.08~2026.06	
CPU	1920 Cores *AMD Genoa + 768 Cores AMD Rome + 528 Cores *Intel FDR5	1920 Cores *New (2024. 12) + 1920 Cores AMD Genoa + 768 Cores AMD Rome + 256 Cores Intel-G4	1920 Cores *New + 3840 Cores AMD Genoa + 768 Cores *AMD Rome + 256 Cores *Intel-G4	* 後續 計算 能量 依計 畫核 定狀 況決 定
GPU	V100 - 32 boards A100 - 8 boards *Current Resources	V100 - 32 boards A100 - 8 boards + 16 boards *Current Resources	V100 - 32 boards A100 - 8 boards *Current Resources	
Storage (PB)	3 *Buy-in every year	6 *Buy-in 3TB every year	9	
Tape (PB)	4 *Buy-in every year	8 *Buy-in 4TB every year	12	

表、計算資源購置規劃表 2025.1

Scientific & HPC Computing Service

- Batch Jobs Computing Service
 - Slurm Work Management System
- Interactive Jobs Computing Service
 - Scalable & Virtualized Service-as-Service (SaaS) Service Model
 - Software on-demand Web-based UI
 - Customized Application Deployment

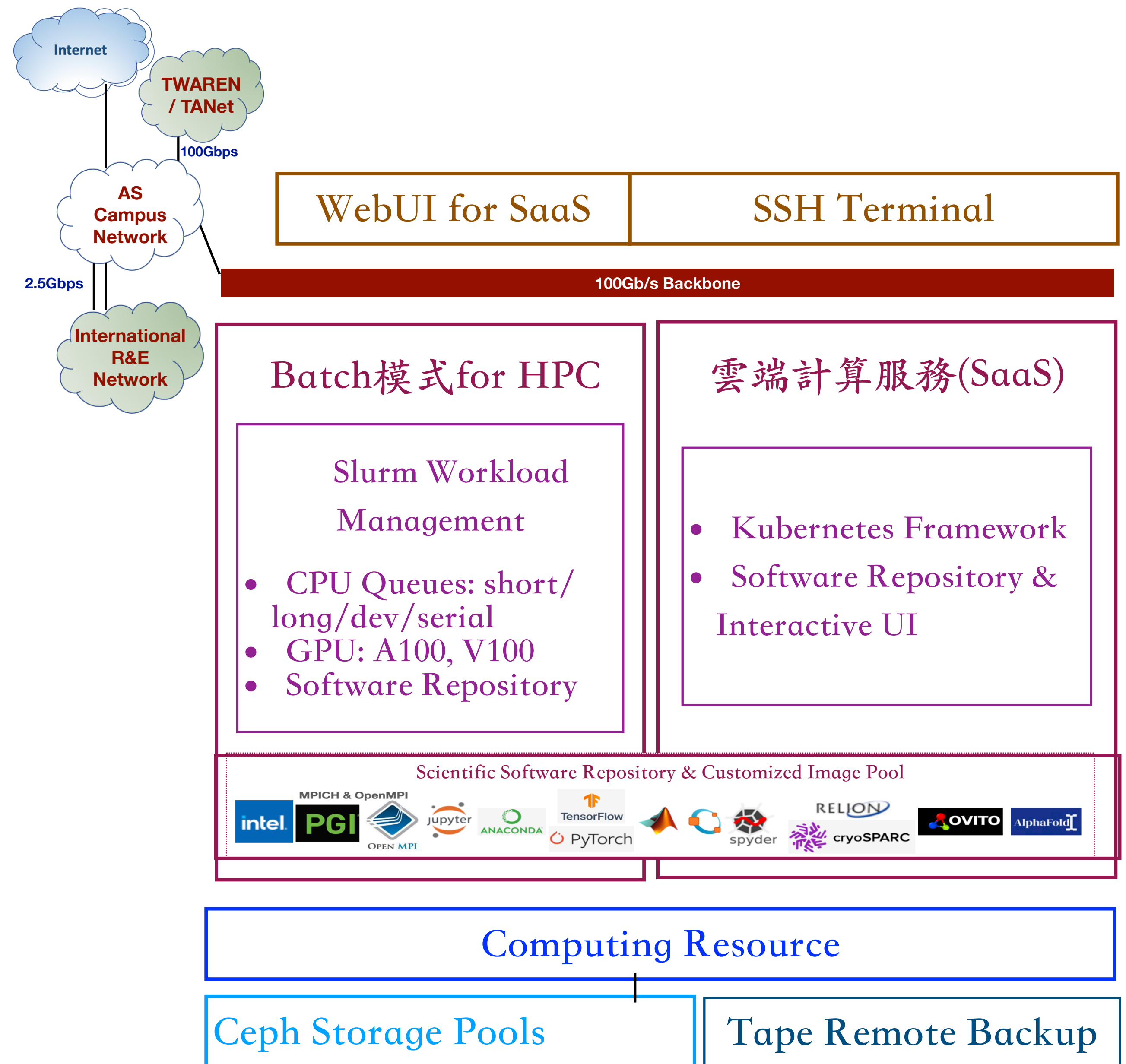

System Architecture of NSTCCore Computing Service

Slurm System Architecture

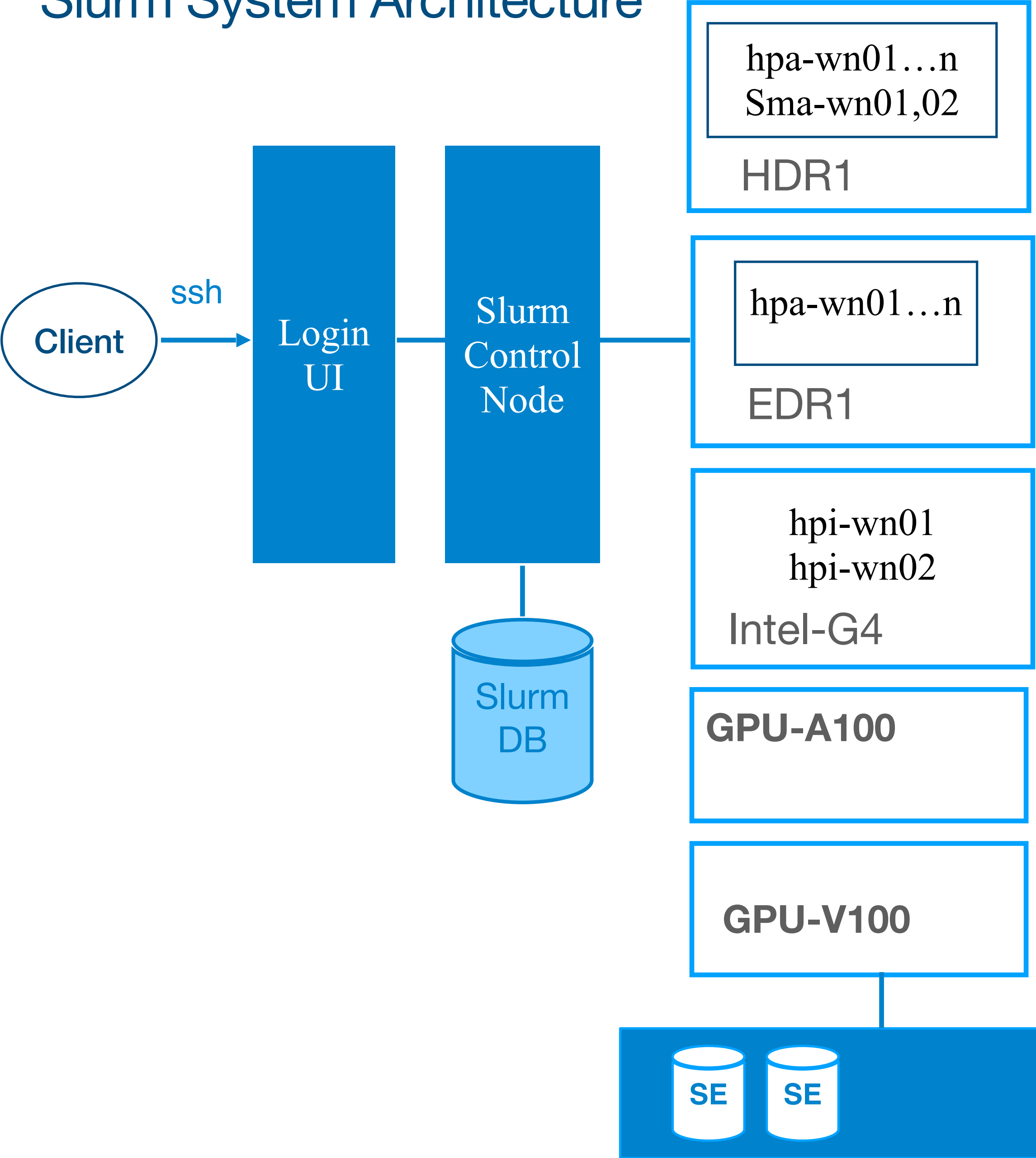

DiCOSApp SaaS Architecture

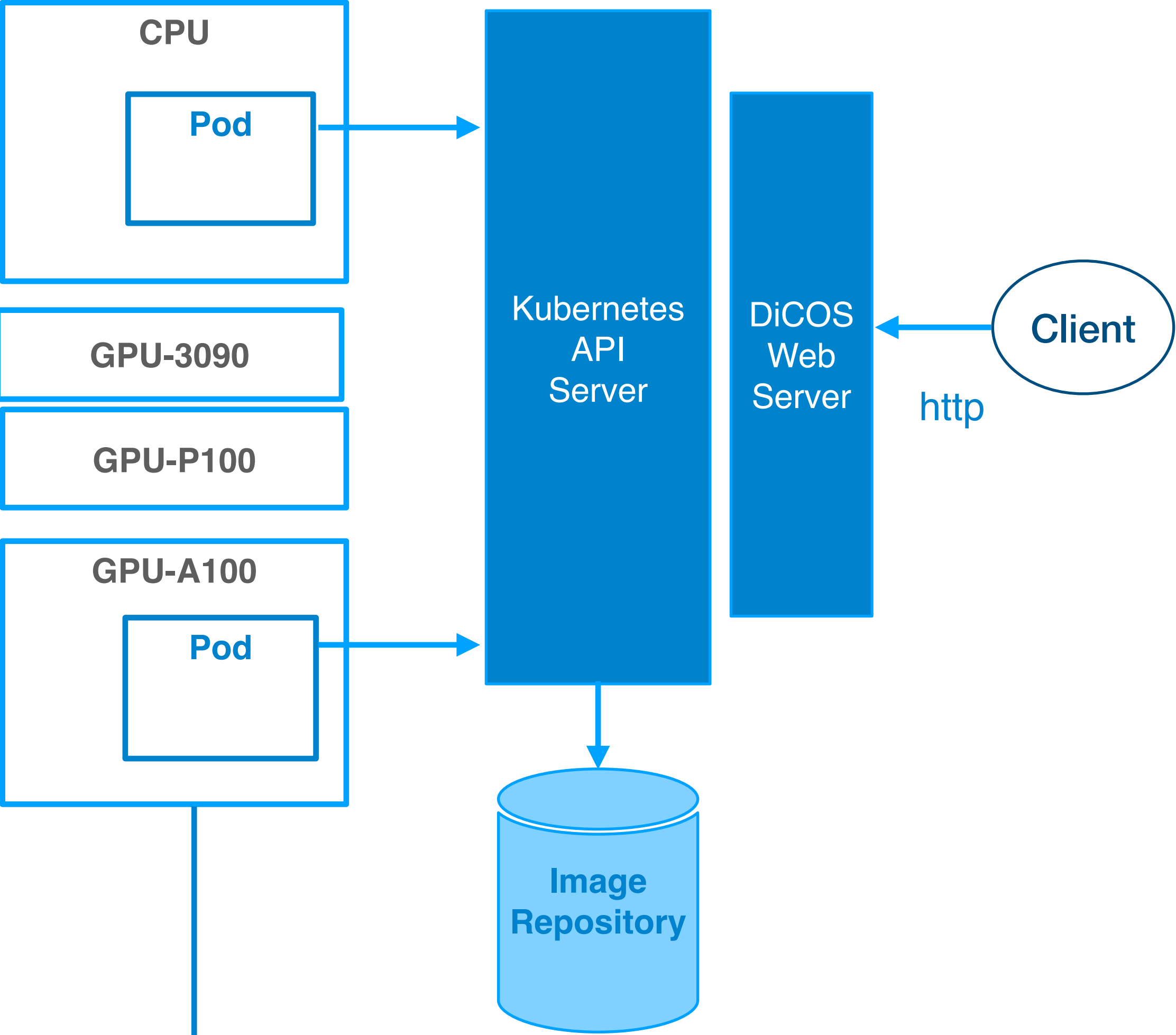

Batch Jobs Computing Service

- Slurm System Architecture
 - Scalable Cluster Management and Job Scheduling System
- Computing Nodes
 - CPU - EDR1 、HDR1 、Intel-G4
 - GPU - A100 、V100
- Jobs Working Space:
 - Ceph Cloud Filesystem
 - Intermediate Space: Local Disk in Worker Nodes

Cluster	CPU	Nodes	Cores-Per-Node	Cores	RAM(GB)	Inter-connection	Local Disk (SSD)
Intel-G4	Intel® Xeon® CPU E5-2650 v4@2.20GHz	22	24	528	128	IB:FDR, Eth:10Gbps	2TB
HDR1	AMD Rome 7662 @2.0GHz	6	128	768	1536	IB:HDR, Eth:100Gbps	1TB
EDR1	AMD Genoa 9654@2.4GHz	20	192	3840	1536	Eth: 100Gbps	2TB

Interactive Jobs - SaaS Computing Service

- Kubernetes and Openstack
 - High extensible and reliable virtual environment
- Customized Application Deployment
- Images Repository
 - JupyterLab and various scientific applications
 - Built by user's requirements
- Software-on-demand Web UI
 - No installation and easy to adopt
- Working Space (* Customized User Data Pool)
 - Ceph Filesystem

SaaS for Virtualized Computing Service

Scientific Software Repository

- Interactive : Ovito(Molecular Dynamics) 、 cisTEM 、 RELION(Medical Image Reconstruction)
- BioMedical : Cryosparc (* License required from users)
- Anaconda Python packages for ML : JupyterLab 、 TensorFlow 、 PyTorch 、 PyRoot 、 DeepMD(Molecular Dynamics)···etc.



When your job needs

- Interactive UI
- Specific OS or Application required
- Dedicate node for rapid development for multi-core or GPU to develop and testing your task

Users' Challenges

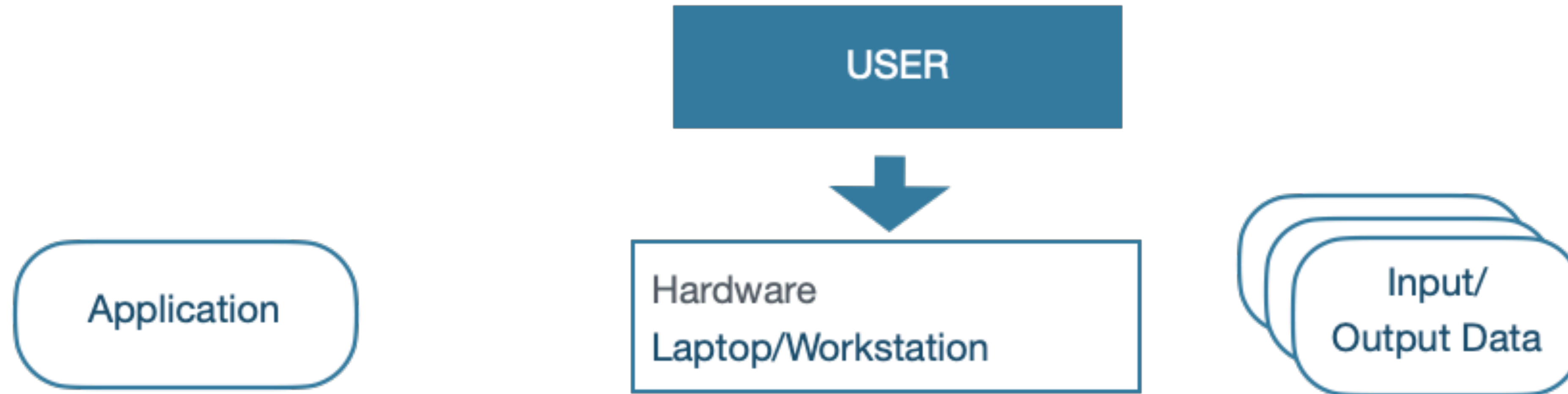

Challenges

- Integration with different hardwares challenge
- rapid software version migrations
- software specific performance issues

- computing scale limited
- Rapid hardware development
- hardware performance tuning... etc.

- Time-consuming Data transfer
- Backup and damage risk
- Rapid data growth

Workflow of User Support

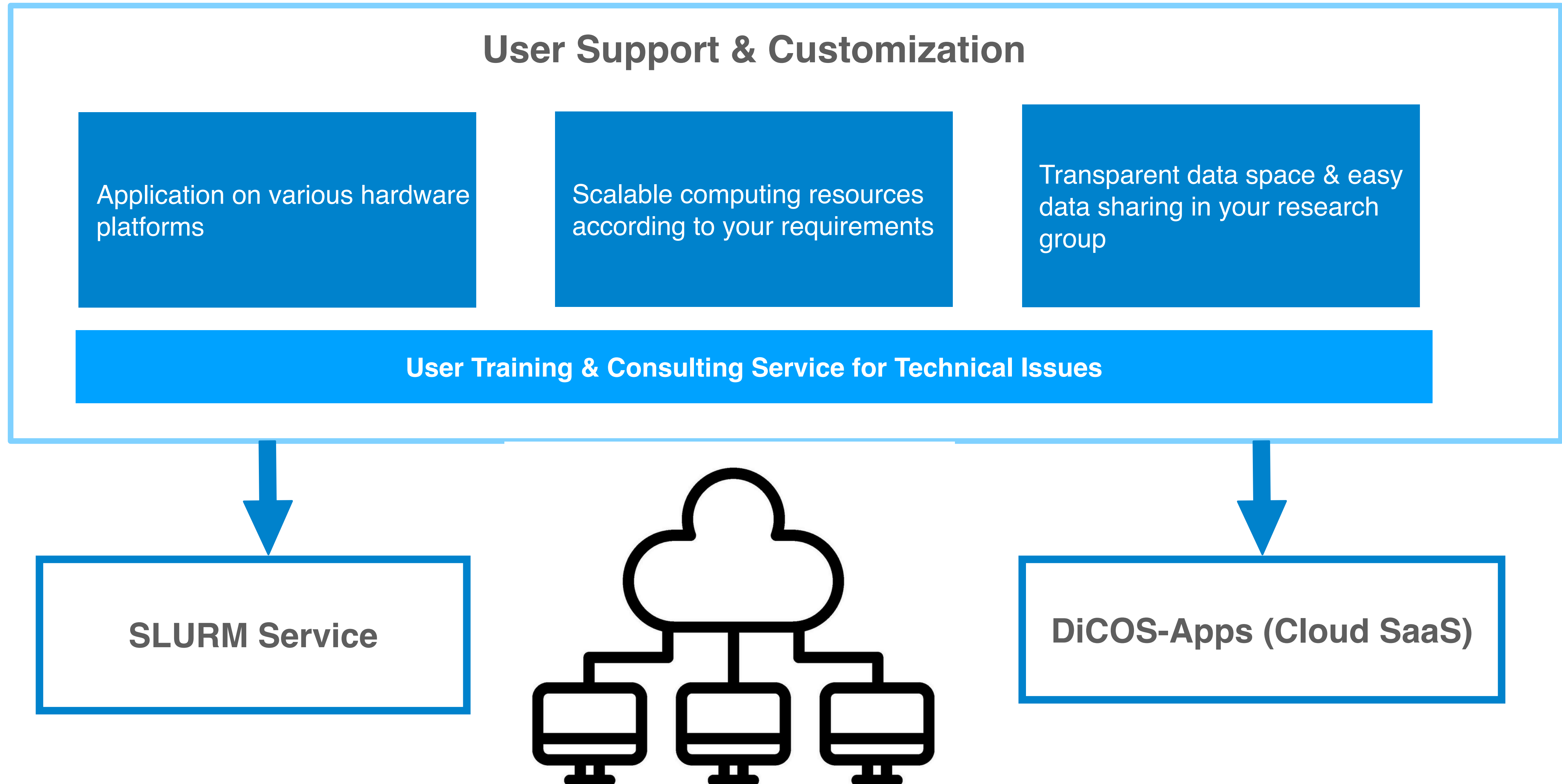

以中研院冷凍電顯中心為例：

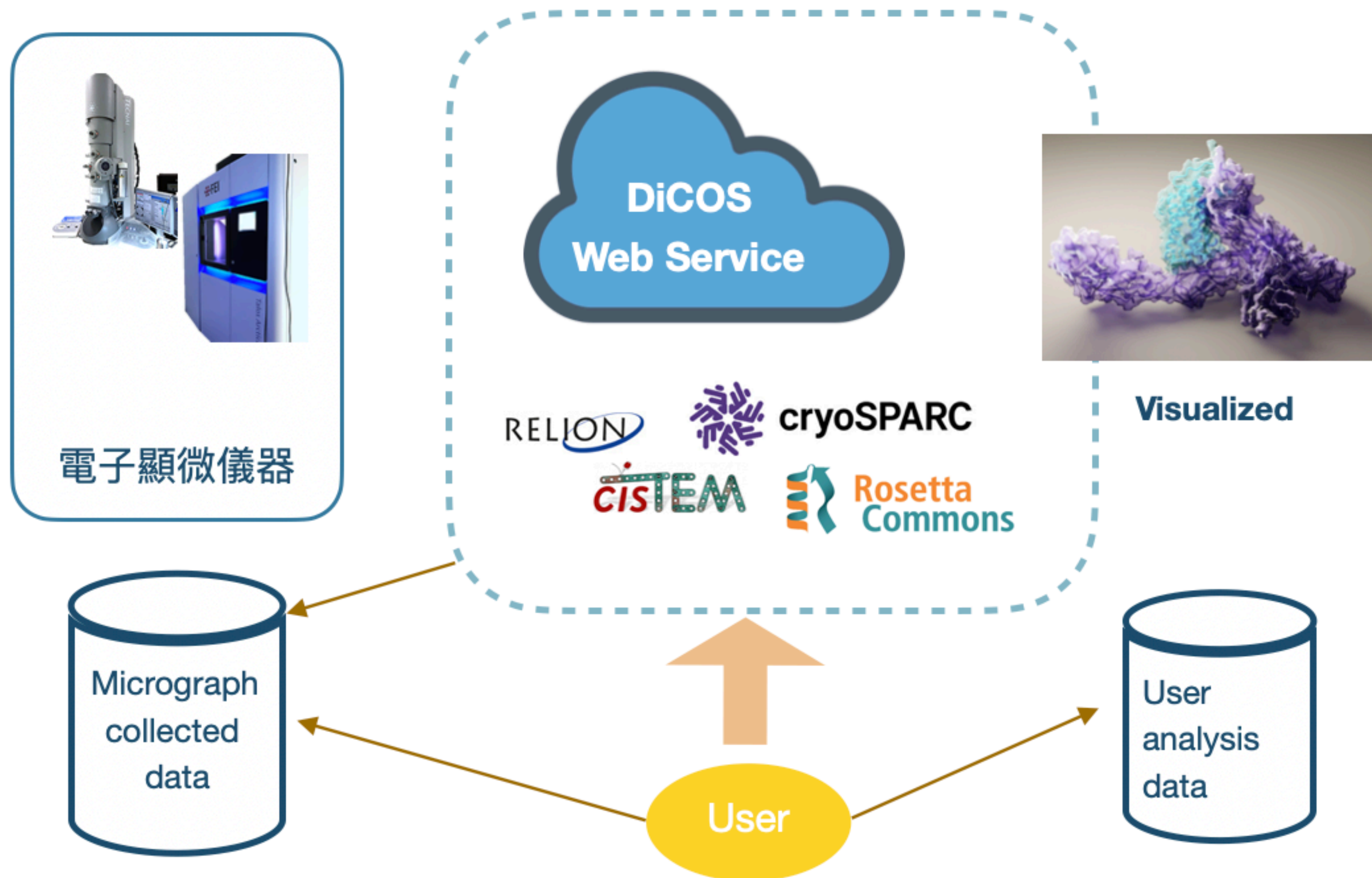

Storage Service

- Ceph Filesystem
 - An open source distributed filesystem
 - High-Throughput

User Home Space

- /dicos_ui_home/{user_account}
- 100GB Free space

Working Space

- /ceph/work/{group_account}
- Every Group has 3TB free space, PI has full permissions for data in this space. Buy more space according to your computing needs, 1TB/days as a purchase unit.

Tape as Backup Service is now in testing phase

- /ceph/project/{group_account}
- Backup and long-term preserved space. Buy as needed. 1TB/years as a purchase unit.

Data Transfer

- Transfer by SFTP via dicos-sftp.twgrid.org

Group & User Management

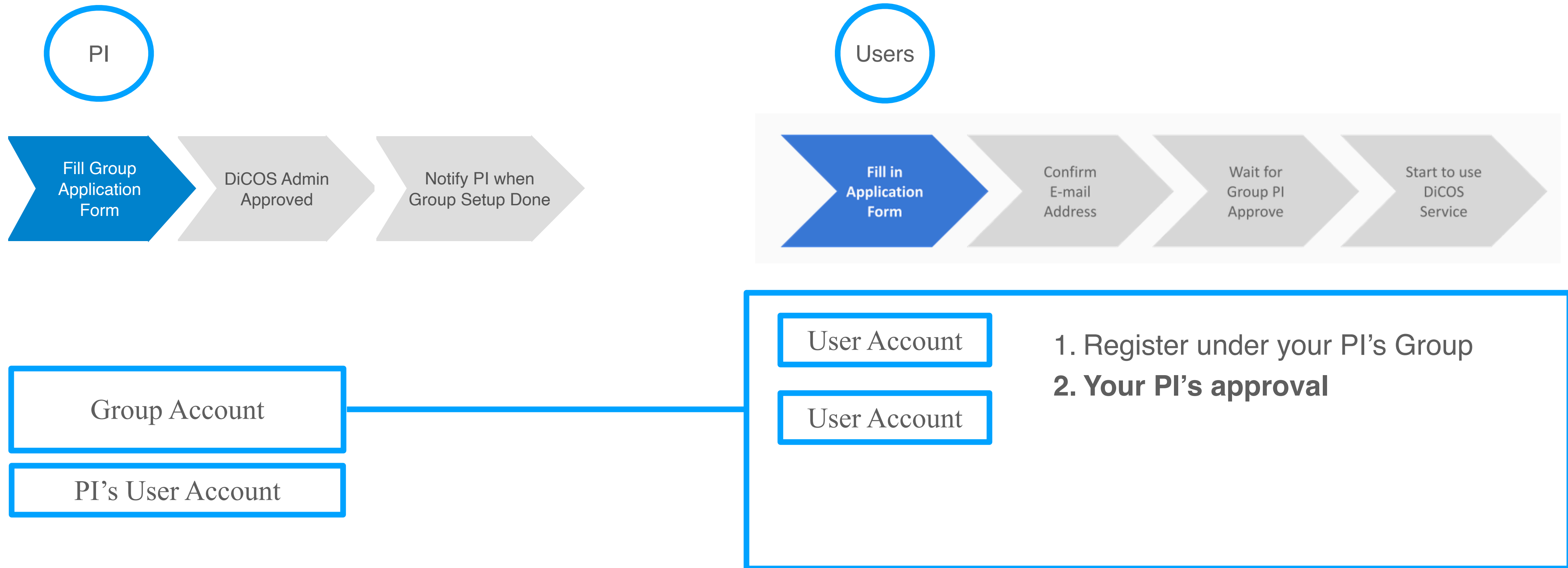

- Group Accounts

- <https://canew.twgrid.org/ApplyAccount/groupcreate.php>

- User Accounts

- <https://canew.twgrid.org/ApplyAccount/ApplyAccount.php>

Apply New Group



If you don't see your group in [Apply Account page](#), please ask your PI to create new group.

The charging mode please see: [ASGC Pricing](#)

Starting from 2023, before the 15th of each month, the accounting report of the previous month will be sent for your reference. Monthly resource usage statistics after January 2022 are also available on the [ASGC website](#).

Group Information

Group	<input type="text" value="Group Name"/>
PI Name	<input type="text" value="First Name"/> <input type="text" value="Last Name"/>
PI Chinese Name	<input type="text" value="Chinese Name"/>
E-mail	<input type="text"/>
Phone	<input type="text"/>
Institute	<input type="text" value="---Choose---"/> <input type="text" value="Please fill with institute Full Name"/>
Country	<input type="text"/>
PI's deputy E-mail	<input type="text"/> <input type="button" value="Add More E-mail"/>

Do your members use **Cryo-electron microscopy**(中研院冷凍電顯設施 (ASCEM))?

Yes No

User Management

Apply Account



After applying this account, you can use the following service:

1. [DiCOS](#)
2. [DiCOSBOX](#)

User Information

Group ▾ [If you don't find your PI in list, please ask your PI to Apply New Group.](#)

Name

E-mail

Backup E-mail

Phone

Institute ▾

Country

Account Information

- The password must **not**:
- Length is less than 8 characters
 - Contain your Account

Account

User Management - Two Factor Authentication

- **Two-Factor Authentication** Support from January 2025
 - Google Authenticator (Install on your mobile device)
 - Get your own associated QR code and scan it to set up for your Google Authenticator
 - Obtain 6-digit verification code to access the computing services.
 - See instructions via <https://canew.twgrid.org/ApplyAccount/howToSave2faCode.php>

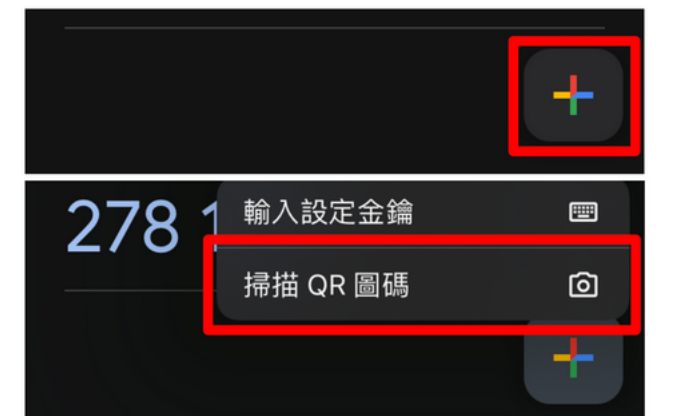

User Management - Account Policy

- Password & Account Expiration (ISO security)
 - 6months validation, password & account expiry notification will be sent on 7, 15 and 30 days to expiration.
 - Account Deletion: Your account & user space(UI_home directory & work directory) will be removed after 6 months of expiration.

User Management - User

- User Profile

- Change Group* (PI approve)

- Change Password*

- <http://canew.twgrid.org/ApplyAccount/nocertModify.php>

- Resource Usage

- Free \$200 Credits for Trial 1 month

- Storage Usage

User Profile

Username **account_name**

Group **group_name**

First Name **your_first_name**

Last Name **your_last_name**

E-mail **your email**

Last Login **time_joined**

Date Joined

Storage Usage **/dicos_ui_home/your_account** Latest Update: 2023-11-14 00:50:02
2.3GB/100GB

/ceph/work/your_group Latest Update: 2023-11-14 00:30:03
0.4TB/4.0TB

[Edit Profile](#) [Change Password](#)

[使用統計摘要\(TOTAL SUMMARY TABLE\)](#)

[使用明細\(DETAILED USAGE ACCOUNTING\)](#)

使用明細(DETAILED USAGE ACCOUNTING)

使用者(username): robert10096901 (Po-Han Tseng) **Free Period: 2024-02-27 08:28:09~2024-03-27 08:28:09, Remain: NT \$199**

[用量異常回報\(submit issue\)](#)

Alert	#Instance	EDR1		
		CPU	GPU	
<input type="checkbox"/>	EDR1 slurm	140	7,220	0

使用者(username): steven20720 (可奕 郭) **Free Period: 2024-03-11 08:44:09~2024-04-11 08:44:09**

Alert	#Instance	A100		EDR1		QDR6		RTX3090		V100	
		CPU	GPU	CPU	GPU	CPU	GPU	CPU	GPU	CPU	GPU
<input type="checkbox"/>	jupyterlabcpu	4				14	0				

User Management - Group

- Members management

- Members list
- Abnormal member usage report
- Member's usage review

使用者 (username)	姓名(name)	Email	Expired Date	Active	Joined Date	Last Login	Storage Usage (UI Home)
chiong	CHAN-HIN IONG	chiong@me.com	Jun. 13, 2024, 00:00 AM	True	Aug. 22, 2018, 00:00 AM	Jul. 31, 2023, 03:41 AM	33.4G/100G <small>Latest Update: 2023-07-31 00:50:03</small>
dickie	Dickie Chang	dickie.chang@twgrid.org	Oct. 12, 2023, 00:00 AM	True	Dec. 15, 2022, 07:16 AM		
eric	嚴漢偉 嚴漢偉	Eric.Yen@twgrid.org	Oct. 18, 2023, 00:00 AM	True	Mar. 11, 2019, 09:13 AM	Jul. 06, 2023, 04:37 AM	0.0G/100G <small>Latest Update: 2023-07-31 00:50:03</small>
ericyen	Eric YEN	Eric.Yen@twgrid.org	Dec. 08, 2023, 00:00 AM	True	Apr. 23, 2013, 00:00 AM	Jul. 24, 2023, 03:22 AM	0.0G/100G <small>Latest Update: 2023-07-31 00:50:03</small>
etomo	etomo etomo	etomo@twgrid.org	Aug. 09, 2025, 00:00 AM	True	Dec. 23, 2020, 09:19 AM	Jan. 22, 2021, 10:16 AM	0.0G/100G <small>Latest Update: 2023-07-31 00:50:03</small>
felixlee	Felix Lee	felix@twgrid.org	Oct. 24, 2023, 00:00 AM	True	Mar. 05, 2013, 00:00 AM	Jul. 27, 2023, 07:29 AM	436.3G/100G <small>Latest Update: 2023-07-31 00:50:03</small>

[使用統計摘要\(TOTAL SUMMARY TABLE\)](#)
[使用明細\(DETAILED USAGE ACCOUNTING\)](#)

- 計算資源使用統計(COMPUTING USAGE OF GROUP) – 預估使用費(INITIAL COST): NT \$15,878

使用者(username)	姓名(name)	CPU (SRU)	GPU (SRU)	預估費用 (Initial Cost Estimation)
chiong	CHAN-HIN IONG	175	7,601	15,552
jyou	Jingya You	1	54	110
rudy	陳侑廷	3	0	6
thwu	Tsung-Hsun Wu	4	101	210
總計	單價SRU=NT\$2	183	7,756	(183+7,756)*2=15,878

- 儲存資源使用統計(STORAGE USAGE OF GROUP) – 預估使用費(INITIAL COST): NT \$417

帳號(ID)	名稱(name)	儲存空間用量(storage(TB))	預估費用(Initial Cost Estimation)	說明(note)
ASGC	Group	0.0	0.0	Group使用空間
chiong	CHAN-HIN IONG	0.0	0.0	User使用空間
jyou	Jingya You	0.0	0.0	User使用空間
rudy	陳侑廷	0.0	0.0	User使用空間
thwu	Tsung-Hsun Wu	4.9	408.3	User使用空間

[使用統計摘要\(TOTAL SUMMARY TABLE\)](#)

[使用明細\(DETAILED USAGE ACCOUNTING\)](#)

使用明細(DETAILED USAGE ACCOUNTING)

使用者(username): chiong (CHAN-HIN IONG)

用量異常回報(submit issue)

Alert	#Instance	A100		FDR5		P100		RTX3090		V100	
		CPU (SRU)	GPU (SRU)	CPU (SRU)	GPU (SRU)	CPU (SRU)	GPU (SRU)	CPU (SRU)	GPU (SRU)	CPU (SRU)	GPU (SRU)
<input type="checkbox"/>	relion311rtx3090	3						151	6,320		
<input type="checkbox"/>	jupyterlabtf24gpu3090	2						11	474		
<input type="checkbox"/>	matlab	2								0	6
<input type="checkbox"/>	jupyterlabgpu26a100	1	1	519							
<input type="checkbox"/>	openaccp100	1				11	282				
<input type="checkbox"/>	FDR5 slurm	2			0	0					
<input type="checkbox"/>	STORAGE USAGE (0.0 TB)										

Pricing for Computing Service

More details in

<https://dicos.grid.sinica.edu.tw/resources>

[https://nstccore.twgrid.org/](https://nstccore.twgrid.org/access.php#pricing)

[access.php#pricing](https://nstccore.twgrid.org/access.php#pricing)

CPU計算服務				
機器名稱	機器規格	計費單位(Per Core/Board-Day) 價格(NTD)	國內非學術單位使用者	國外學術單位使用者
intel-g4	Intel(R) Xeon(R) Gold 6448H	1.4	加計 50%	加計 50%
EDR1	AMD Genoa 9654 @2.4GHz	1.2		
HDR1	AMD Rome 7662 @2.0GHz	1		
GPU計算服務				
A100	NVIDIA A100	120	加計 50%	加計 50%
RTX4090	NVIDIA RTX-4090	60		
RTX3090	NVIDIA RTX-3090	40		
RTX3090 (Dedicated for ASCEM user)	NVIDIA RTX-3090	40		
V100	NVIDIA V100	35		
P100	NVIDIA P100	8		
1080Ti	NVIDIA GTX-1080Ti	1		
儲存與擷取服務				
--	\$1000 NTD/TB-Year		加計 20%	加計 50%
--	\$3 NTD/TB-Day			
資料傳輸				
--	目前未納入計費			
進階服務				
--	依據所需人時計算。額外需開發之軟體、系統或使用介面等，將另按工時計費(每 168 man-hr 為 NT\$ 120,000)			

User Management - PI's Billing Management

- Resource Usage Management
 - Resource Usage
- Budget & Payment Management
 - Monthly Bill will be delivered every month
 - <https://dicos.grid.sinica.edu.tw/accounting/bill/>
 - Payment Management
 - How to Make Payment
 - <https://nstccore.twgrid.org/access.php#pricing>

使用者資源使用統計表

Resource Usage Monthly Report

請選擇月份(month)

Reporting Period: 01 - 13 January, 2025

PI Group : 尤靖雅 (Group ID: ASGC)

單位/所別(Institute) : 中央研究院 物理研究所

目前付款方式(How to charge) : 院內預算系統轉帳作業

儲存(save)

選擇付款方式

院內預算系統轉帳作業

其他付款方式

使用統計摘要(TOTAL SUMMARY TABLE)

使用明細(DETAILED USAGE ACCOUNTING)

• 計算資源使用統計(COMPUTING USAGE OF GROUP) – 預估使用費(INITIAL COST): NT \$1,495

使用者(username)	姓名(name)	CPU	GPU	預估費用 (Initial Cost Estimation)	說明(note)
jyou	Jingya You	1	0	5	
mandy4318	Ming-Jyuan Yang	1	0	3	
thwu	Tsung-Hsun Wu	195	24	1,331	
yiruchen0101	陳怡如	151	0	156	
總計	單價請參考Resources頁面	348	24	1,495	

Technical Support

- Help Desk & Service Notification
 - Rocketchat online chat - <https://rocketchat.twgrid.org/channel/general> 
 - Email - dicos-support@twgrid.org
 - Portal - <https://nstccore.twgrid.org>
 - Release up-to-date services status, group usage, pricing and technical relevant information